

escea.

GAS FIRE USER GUIDE



ST500

NZ

www.escea.net

630003_2 Manual_User_ST500_NZ

Any installation or service work carried out on this appliance must only be done by a recognised and qualified gas fitter.

The data plate for this appliance, containing technical information and specifications, can be found to the right of the control tray, near the base of the fire. To access this, the fascia must be removed.

Escea recommends the ST500 is inspected and serviced by a qualified Gas Fitter once every twelve (12) months.

DO NOT PLACE ARTICLES OR FURNISHINGS ON OR AGAINST THIS APPLIANCE.

DO NOT OPERATE THE FIRE IF THE GLASS HAS BEEN BROKEN, DAMAGED OR IT IS NOT PROPERLY POSITIONED/HOOKED ONTO THE FIRE

DO NOT OPERATE THE FIRE WITH THE FASCIAPANELS REMOVED.

THIS APPLIANCE IS NOT INTENDED FOR USE BY YOUNG CHILDREN OR INFIRM PERSONS UNLESS THEY HAVE BEEN ADEQUATELY SUPERVISED BY A RESPONSIBLE PERSON TO ENSURE THAT THEY CAN USE THE APPLIANCE SAFELY.

THIS APPLIANCE MUST BE INSTALLED IN ACCORDANCE WITH THE MANUFACTURERS WRITTEN INSTRUCTIONS.

THE GLASS SURFACE ON THE FRONT OF THE FIREPLACE IS CONSIDERED A WORKING SURFACE, AND AS SUCH IS HOT AND CARE MUST BE TAKEN NOT TO TOUCH THIS SURFACE. IT IS RECOMMENDED A SECONDARY GUARD IS FITTED IN PLACES WHERE THERE ARE YOUNG CHILDREN OR AGED OR INFIRM PERSONS.

CURTAINS SHOULD NOT BE POSITIONED ABOVE THE FIREPLACE AND ANY PROTRUDING LEDGES MUST NOT COME WITHIN THE MINIMUM DISTANCES SPECIFIED IN SECTION 5.1 OF THE INSTALLATION MANUAL SUPPLIED WITH THIS APPLIANCE.

escea. NZ LTD
31 Devon St, PO Box 5277
Dunedin, New Zealand

E-mail: info@escea.net
Web: www.escea.net
Phone: +64 03 479 0302 Fax: +64 03 479 0301

escea.

Contents

> Basic Operation	
Turning the ST500 on and off	1
Altering the flame height	2
Setting and adjusting the thermostat	3
Locking the Remote Control	4
> Clearances	6
> Cleaning and Maintenance	8
> Normal operating Sounds and Smells	10
> Warranty Information	11

The ST900 electronic control system is designed to work within the temperature range of 0°C to 60°C, with a humidity level that is non condensing. This is to ensure safe operation of the electronic and gas control system.

If the fireplace is subjected to an environment with temperatures very close to or exceeding these temperature limits (irrespective of if the fireplace is on or off at the time) the fireplace may not start up until the temperature returns back to within the operating range.

To remedy this the environmental temperature should be addressed and the fireplace control system given time to adjust accordingly. The fireplace should then function correctly.

1

Basic Operation

The escea ST500 remote control allows you to turn the fire ON and OFF, control the flame height in the Manual mode, or control the room temperature in the Thermostat mode. The remote has a maximum range of 10 meters, and because the remote works by radio frequency, it does not need to be aimed at the ST500 for it to operate.

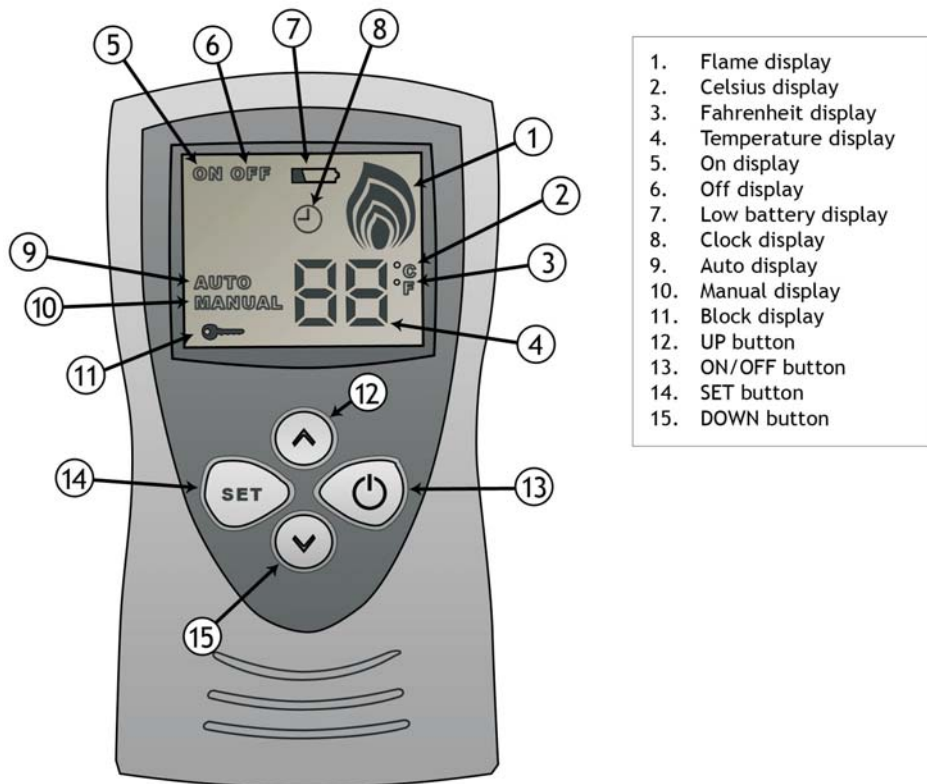

Switching on the ST500

To turn on the ST500, push the ON/OFF button (13), and the ON display (5) will start to blink on the screen. Now push SET (14) and the pilot will start sparking and gas will start flowing to the pilot, which should then be lit within a few seconds.

The pilot flame display (1) will blink for 10 seconds while the ignition process takes place - No other button should be pressed during this time. The remote control is now in MANUAL mode, and ready to be used.

If the pilot flame fails to ignite, you must turn OFF the ST500 from the remote and start the process of turning it ON again.

Switching off the ST500

To turn off the ST500, push the ON/OFF button (13) and the OFF display (6) will start blinking. Push the SET button (14) again to shut down the gas flow to the ST500 and switch it off. The OFF display (6) will now appear in the display.

Increasing and Decreasing the Flame Height

While in MANUAL mode (10), push the UP button (12) or the DOWN button (15) to increase or decrease the flame height. The flame display (1) shows 4 possible flame positions:

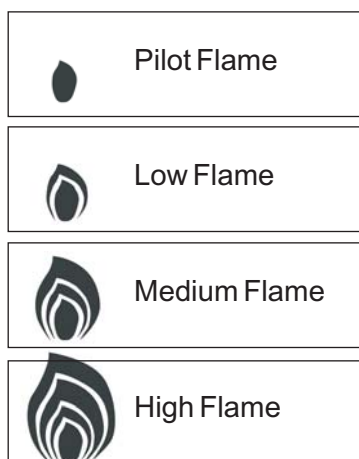

If the UP button (12) is pushed while the flame is in the High flame position, nothing will happen. Similarly, if the DOWN button (15) is pushed while the flame is in the Pilot flame position, nothing will happen.

If your fire uses LPG, there will be minimal discernable difference between the low, medium, and high flame setting.

3

Basic Operation

Turning on the Thermostat

While the MANUAL display (10) is showing, push the SET button (14) and the AUTO display (9) will start blinking. Push the SET button (14) again and the AUTOMATIC mode is set, and the temperature display (4) will start blinking.

When the temperature display (4) is blinking you will be able to adjust the room temperature by pushing the UP button (12) or the DOWN button (15) to adjust the desired room temperature, and push SET (14) to select the temperature

Adjusting desired temperature in Thermostat mode

When you want to change the set room temperature while In the AUTOMATIC mode and the AUTO display (9) is showing, you can push the UP button (12) or the DOWN button (15). At that time the temperature display (9) will start blinking. Depending if you want to increase or decrease the set room temperature you must continue pushing the UP button (12) or the DOWN button (15) until the new desired room temperature appears in the temperature display (4). At that time you must push the SET button (14) to set that temperature as the desired room temperature.

If the SET button (14) is not pushed, the temperature display (4) will stop blinking in a few seconds and the set room temperature will remain unchanged.

Turning off the Thermostat

While in the AUTOMATIC mode and the AUTO display (9) is showing, push the SET button (14), and the MANUAL display (10) will start blinking. Push the SET button (14) again, and the MANUAL display (10) will stay lit. This means that the manual option is now activated.

If the Pilot Flame is Extinguished:

If the pilot flame is extinguished then no attempt to relight the gas should be made until at least 3 minutes have passed.

Changing the display from Fahrenheit to Celsius

If the temperature is set to Fahrenheit, push the ON/OFF button (13) and the ON (5) or OFF display (6) will start blinking. After that push the ON/OFF button (13) and the UP button (12) together.

The temperature scale in the display will change to Celsius (2).

To lock the Remote Control buttons

To lock the remote control, push the ON/OFF button (13) and the ON button (5) or OFF button (6) will start blinking, you then need to push the ON/OFF button (13) and the DOWN button (15) together. The key display (11) will now appear.

You can lock the remote control in the ON or OFF positions and during either the MANUAL or the AUTOMATIC mode. The LOCK features is designed as a CHILD SAFETY feature.

If for any reason you have a LOCKED REMOTE CONTROL while the ST900 is on and you need to turn it off, take one of the batteries of the electronic control out of the battery box.

To unlock the Remote Control buttons

To unlock keys while the key display is showing, you have to push the ON/OFF button (13) and the DOWN button (15) together. After that the key display (11) should disappear.

Interrupted Electrical Supply

If for any reason the electrical supply to the appliance is lost, once power is restored the appliance must be shut off as per instructed on page 2 of this document, and then switched on again as per page 1.

DO NOT DROP THE REMOTE.

Dropping the remote may result in a cracked LCD screen or malfunctioning components. Escea is not liable for damage to the remote, however replacement remote controls are available.

5

Basic Operation

Operation from the Touch Pad

The touch pad is intended to be used for service/diagnostic purposes and to operate the fire in the event that the remote handset becomes lost or inoperative.

If you remove the fascia (see Page 6), you will find an electronic touch pad in the centre bottom of the fire. The touch pad features the basic operations of the fire: On, off, and manual adjustment of the flame height.

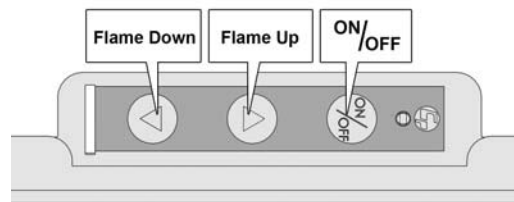

To turn on the ST500, push the ON/OFF button on the touch pad. The LED will start to blink while the pilot starts to spark. The pilot should be lit within a few seconds, during which time the LED will blink while the ignition process takes place. The ST500 is now in the 'Manual' mode and ready to be used.

While the pilot is lit, press the 'Flame Up' or 'Flame Down' button to alter the flame height. The LED will flash once to confirm the flame height has been adjusted. The ST500 has 4 flame positions: Pilot only, Low, Medium, and High flame height.

If the 'Flame Up' button is pressed while the unit is in the 'high' flame position, nothing will happen. Similarly, if 'Flame Down' is pressed while the unit is in the 'pilot' flame position, nothing will happen.

To shut down the gas flow to the ST500, press the On/Off button and the LED will begin to blink.

If while using the Remote control in the Manual mode, you push any button on the Touch Control, the unit will receive the command of the touch control and follow it. If the command is to turn Off the ST500, the fire will be turned Off however the display on the Remote will continue to show the unit as On. In this case, to be able to use the remote control again you must turn the fire Off again via the Remote Control.

If you push a button on the touch pad while using the remote control in the Automatic/ Thermostatic mode, the ST500 will follow the command from the touch control, while the remote control display continues to show the mode as Automatic. If you do not push any further buttons on the touch pad, the remote control will continue working in Automatic / Thermostatic mode after 6 minutes.

Cabinet Clearances

There must be a minimum of 100mm from the sides of the fascia to any protruding side walls or cabinetry.

Television Positioning Considerations

It is becoming common practice for consumers to mount flat screen TV's above their gas fireplace.

Most TV manufacturers have specified in their instructions that the TV should not be installed on, near or above a heat source. For this reason TV location decisions rest solely with the householder and Escea will not be held liable for any adverse affects on a TV located near to an Escea fireplace that may be caused by heat.

The drawings below are suggestions that may be used as a GUIDE for those consumers who do decide to locate their TV above an ST500 gas fire. These drawings show ways to reduce the amount of warm air rising off the fireplace and onto the TV.

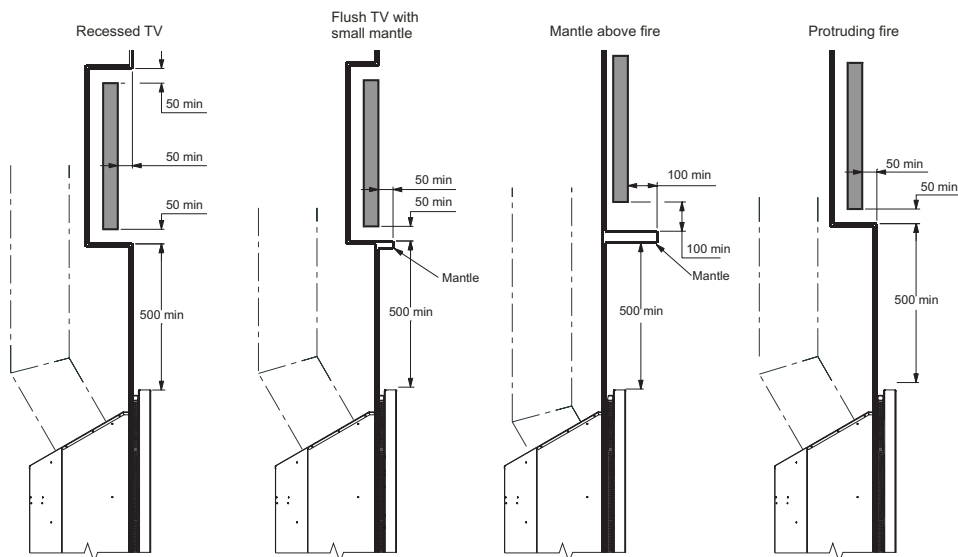

7

Clearances

The material that the wall and mantle are made from will also affect the operating temperature of the TV so it is the customers responsibility to satisfy themselves that their TV mounting and mantle design will not exceed the listed maximum operating temperature of their electronic goods.

ST500 Mantle Clearances

If any part of the installation (mantle, wall or cavity) is constructed from **COMBUSTIBLE** materials, the diagram below shows the maximum allowable size for mantles or protruding surfaces mounted above an ST500.

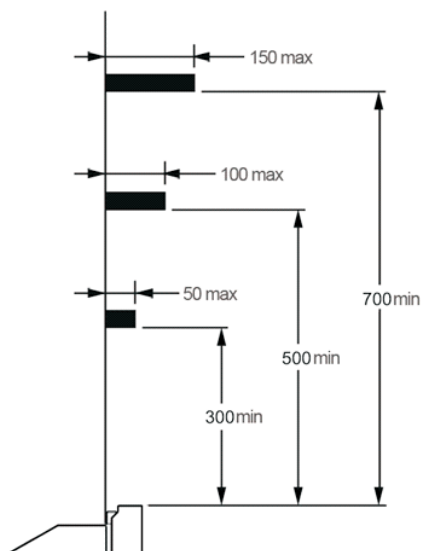

If the entire installation (mantle, wall and cavity) is constructed from **NON-COMBUSTIBLE** materials, then the clearances to mantles or protruding surfaces mounted above an ST500 may be as shown by the shaded area in the diagram below

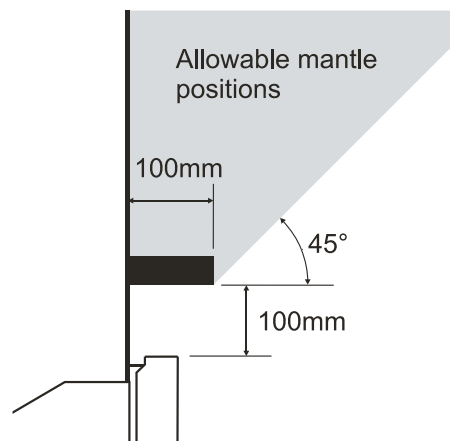

Annual Servicing

Your ST500 Decorative Gas Fireplace requires that annual service checks be carried out by a Registered Installer to ensure that it will continue to operate in a safe manner.

Please ensure that you schedule annual service checks for your ST500 with your local Registered Installer.

Removing the ST500 Fascia

Ensure the fascia is allowed to cool before handling.

The ST500 fascia attaches to the fire by four hooks. To remove the fascia, simply lift it upwards 15-20mm, and pull towards you. Care should always be taken when handling the fascia.

To replace the fascia, line up the four hooks with the matching receptacles on the fire and push the fascia into place and let it drop down as shown to the right, the fascia should now be securely in position.

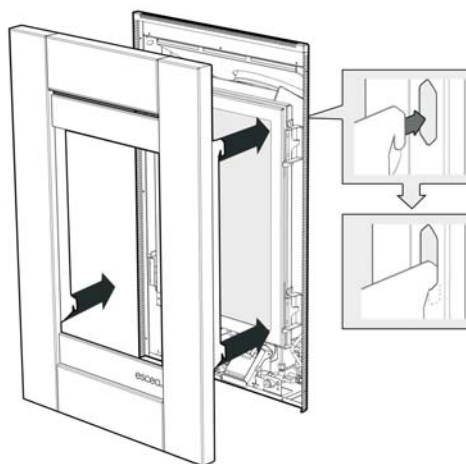

Removing the ST500 Glass Assembly

Ensure the ST500 is allowed to cool before continuing with the following procedure.

Pull the four hooks shown below towards you and then away from the glass to release the glass frame underneath the hook.

Lift the glass assembly towards you to clear the locating supports and place it flat upon some newspaper or a sheet of cardboard to protect your floor coverings.

9

Cleaning and Maintenance

Follow the instructions on the previous page in reverse to refit the glass assembly to the fireplace.

Do not operate the appliance if the glass has been broken, damaged, or the glass is not properly positioned/hooked onto the appliance.

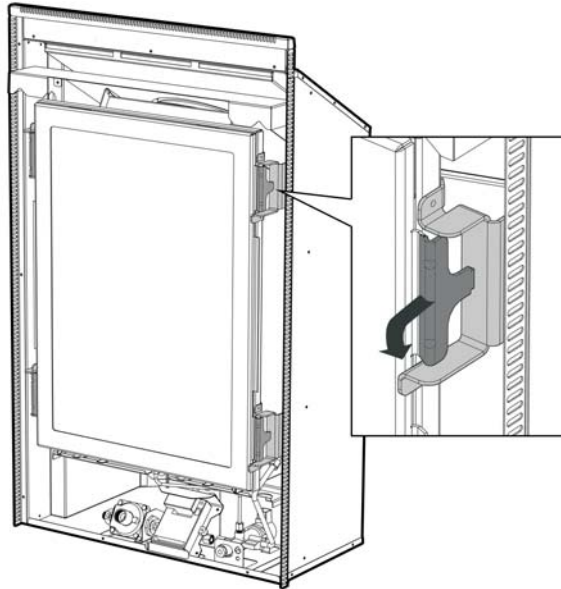

Cleaning your ST500

The unit must be cold before starting any form of maintenance or cleaning.

If your Stainless Steel fascia requires cleaning, 3M Stainless steel cleaner (or equivalent) is recommended.

If your Powder Coated (painted) fascia requires cleaning, you must only use a damp cloth to give it a gentle wipe. Never ever rub the fascia.

The glass can be cleaned using standard window cleaner. If you wish to clean the inside of the glass, you can remove the glass assembly by following the instructions on the next page.

Take care while cleaning the glass so as not to interfere with or damage the fibreglass gasket material on the glass assembly.

Fuel Bed Media

Some discolouration of the coals may occur over time, particularly on white coals. The gravel or driftwood layout and the quantity of material contained therein must not be altered.

Note: Each time the fire is lit from cold the glass will fog up with condensation. This is normal and the condensation will disappear within a few minutes once the glass heats up.

Sounds

It is possible that you will hear some sounds from your gas appliance. This is perfectly normal due to the fact that there various types of materials used within your appliance. Listed below are some examples. These are all normal operating sounds and should not be considered as defects in your appliance.

Gas Control Valve:

As the gas control valves turn ON and OFF, a dull clicking sound may be audible, this is normal operation of a valve. When the fire is switched off after being run for a while, there may be popping and fluttering noises as the residual gas in the burner burns away. These are normal and should be no cause for concern.

Unit Body / Firebox:

Different types and thickness' of steel will expand and contract at different rates resulting in some "dull drumming" and "ticking" sounds being heard throughout the cycling process.

Smells

The first few times the unit is operated, the unit may release an odour and the flames may appear orange caused by the curing of the paint, the burning off of the starch in the gas coals and the oils in the metal. This is a temporary curing process which will disappear with use.

WARRANTY TERMS & CONDITIONS:

Provided that the Product is installed as per ESCEA's Installation Manual and the step by step warranty procedure has been followed as per instructions issued by ESCEA, (documented in the Agent Manual), and the product is operated and maintained in accordance with ESCEA operating and maintenance instructions, then for the first period of twelve (12) months from the **date of purchase** ESCEA will pay the cost of repairing or replacing any part of the Product that is deemed by ESCEA to be faulty.

For the second period of twelve (12) months from the **date of purchase** ESCEA will supply replacement parts only, without charge.

Parts and Labour for the first twelve (12) months:

- a) ESCEA, at its sole discretion, may modify, adjust, repair, or replace the faulty products. The warranty period on parts and labour shall be for twelve (12) months from the date of purchase.
- b) Labour costs will only be reimbursed when ESCEA specified procedure has been followed, and ESCEA has authorised service work before it was carried out.

Parts Only for the second twelve (12) months:

- a) ESCEA, at its sole discretion, will provide replacement parts to the Distributor, retailer or repair service. Faulty parts **MUST** be returned to ESCEA. The parts only warranty period shall be for twelve (12) months and will commence twelve (12) months after **the acceptance date** of the Products by the ESCEA retailer.

General Terms and Exclusions:

1. All repairs made within the Limited Warranty period shall be covered by this Limited Warranty for a period of three (3) months from the date of completion of the repair, or for the remainder of the overall Limited Warranty period, whichever is the longer.
2. If the buyer or any other party modifies any part of the Product within the Limited Warranty period without the prior written consent of ESCEA then the Limited Warranty shall be void. ESCEA may, at its sole discretion, decide that the Limited Warranty is void in relation to any part of the product, which has been modified.
3. ESCEA must be notified of all claims under this Limited Warranty as soon as possible, but in any event not later than two (2) weeks of the claimant becoming aware of the circumstance giving rise to the claims.

4. No ESCEA Distributor, retailer, employee or other third party is authorized to make any modification, extension, or addition to this Limited Warranty, whether verbal or written.
5. ESCEA reserves the right to discontinue products or make substitutions, in such event, the buyer may receive a substitute product or a cash refund at ESCEA'S sole discretion, if a replacement for the product covered by this Limited Warranty is no longer available.
6. ESCEA is not responsible for damage arising from failure to follow instructions for the product's installation, maintenance and permitted and proper use. The Limited Warranty does not cover damage caused by use with non-ESCEA products or damage caused by accident, abuse, misuse, weather, fire, flood, earthquake or other external causes. Products where an ESCEA serial number has been removed or defaced, cosmetic damage, including but not limited to scratches, and normal fair wear and tear are not covered as well.
7. This warranty does not cover installation of the fire into wet areas such as bathrooms or areas of very high humidity.